

ACVATIX™

Rotary actuators for ball valves

GLB..9E



Electromotoric rotary actuators for open-close, three-position or modulating control. Used in heating, ventilation and air conditioning plants.

- For 2-port and 3-port control ball valves, internally threaded connections (VAI61.. and VBI61..) or externally threaded connections (VAG61.. and VBG61..), DN15 to DN50
- For open/close ball valves 2-port and changeover ball valves 3-port, internally threaded connections (VAI60.. and VBI60..) or externally threaded connections (VAG60.. and VBG60..), DN15 to DN50
- Nominal torque 10 Nm
- Operating voltage AC 24 V ~ / DC 24...48 V = or AC 100...240 V ~
- Pre-wired with 0.9 m long connection cables

Features

- Brushless, robust DC motors ensure reliable operation regardless of load.
- The rotary actuators do not require an end position switch, are overload proof, and remain in place upon reaching the end stop.
- The gears are maintenance free and low noise.
- Suitable for use with modulating controllers (DC 0/2...10 V), open-close or three-position controllers.
- We recommend a minimum pulse length of 500 ms on rotary actuators operated with 3-point control to ensure continuous and accurate operation.

Functions

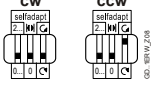
GLB..	AC 24 V ~ / DC 24...48 V ==	141.9E	161.9E
	AC 100...240 V ~	341.9E	—
	Control type	Open-close / three-position	Modulating control (0/2...10 V)
Rotary direction	<p>Clockwise or counter-clockwise direction depends ...</p> <p>... on the type of control</p> <p>... on the setting of the rotary direction DIL switch.</p>  <p>With no power applied, the actuator remains in the respective position.</p>		<p>... on the setting of the rotary direction DIL switch</p>  <p>... on the positioning signal.</p> <p>The actuator remains in the achieved position:</p> <p>... if the control signal is maintained at a constant value</p> <p>... for loss of operating voltage.</p>
	NC (normally closed) ball valve	NC (normally closed) ball valve	
	<p>Signal on Y1</p> <p>– rotation counter-clockwise</p> <p>– ball valve opens</p> <p>Signal on Y2</p> <p>– rotation clockwise</p> <p>– ball valve closes</p>	<p>DIL 2 set to “counter-clockwise” (ccw)</p> <p>Flow = 0% at Y = 0 V</p> <p>Flow = 100% at Y = 10 V</p>	
	NO (normally open) ball valve	NO (normally open) ball valve	
	<p>Signal an Y2</p> <p>– rotation clockwise</p> <p>– ball valve closes</p> <p>Signal on Y1</p> <p>– rotation counter-clockwise</p> <p>– ball valve opens</p>	<p>DIL 2 set to “clockwise” (cw)</p> <p>Flow = 100% at Y = 0 V</p> <p>Flow = 0% at Y = 10 V</p>	
Position indication: Mechanical	Rotary angle position indication by a position indicator/hand lever.		
Position indication: Electrical	Output voltage U = DC 0/2...10 V is generated proportional to the rotary angle. U depends on the rotary direction of the DIL switch setting.		
Self-adaptation of linear span	When self-adaptation is active, the actuator automatically determines the mechanical end positions of the linear span.		
Manual adjustment	The rotary actuator can be manually adjusted by pressing the gear train disengagement button.		
Rotary angle limitation	The rotary angle of the shaft adapter can be limited mechanically with a socket head cap screw.		

Housing

The housing consists essentially of flame retardant, non brominated, non chlorinated glass fibre reinforced plastic.

Type summary

Type	Stock no.	Control	Operating voltage	Positioning signal Y	Position indicator U = DC 0...10 V ==	Self-adaption of rotational angle range	Aux. switches	Rotary direction switch
GLB141.9E	S55499-D204	Open-close or three-position	AC 24 V ~ / DC 24...48 V ==	-	-	-	-	yes
GLB341.9E	S55499-D205		AC 100...240 V ~					
GLB161.9E	S55499-D277	Modulating	AC 24 V ~ / DC 24...48 V ==	DC 0/2...10 V ==	yes	yes	-	

Accessories / Spare parts

Individual spare parts are not available. Components of the accessory kit ASK77.3¹⁾, available as an accessory, can however be used for spare parts.

Description	Components
ASK77.3 Accessory Kit BV for GLBxx1.9E	Mounting bracket (base plate) Axle with sleeve and spring Manual lever with locking clip

¹⁾ Can also be used as rotary actuator for ball valves together with the actuator for air dampers G..B.1E.

Equipment combinations

GLB..9E and VA..61.. 2-port control ball valves

Control ball valves with:						GLB..9E	
internal threads ¹⁾	Rp	external threads ²⁾	G..B	k _{vs} [m ³ /h]	DN	Δp _{max}	Δp _s
-	-	VAG61.15..	G 1 B	1...6.3	15	350	1400
VAI61.15..	Rp ½"	-	-	1...10	15		
VAI61.20..	Rp ¾"	VAG61.20..	G 1 ¼ B	4...10	20		
VAI61.25..	Rp 1"	VAG61.25..	G 1 ½ B	6.3...16	25		
VAI61.32..	Rp 1¼"	VAG61.32..	G 2 B	10...25	32		
VAI61.40..	Rp 1½"	VAG61.40..	G 2 ¼ B	16...40	40		
VAI61.50..	Rp 2"	VAG61.50..	G 2 ¾ B	25...63	50		

GLB.. 9E and VB..61.. 3-port control ball valves

Control ball valves with:						GLB..9E	
internal threads ¹⁾	Rp	external threads ²⁾	G..B	k _{vs} [m ³ /h]	DN	Δp _{max}	Δp _s
VBI61.15..	Rp ½"	VBG61.15..	G 1 B	1.6...6.3	15	350	-
VBI61.20..	Rp ¾"	VBG61.20..	G 1 ¼ B	4...6.3	20		
VBI61.25-10	Rp 1"	VBG61.25-10	G 1 ½ B	10	25		
VBI61.32-16	Rp 1¼"	VBG61.32-16	G 2 B	16	32		
VBI61.40-25	Rp 1½"	VBG61.40-25	G 2 ¼ B	25	40		
-	-	VBG61.50-40	G 2 ¾ B	40	50		

Control ball valves with:					DN	GLB..9E	
internal threads ¹⁾	Rp	external threads ²⁾	G..B	k _{vs} [m ³ /h]		Δp _{max}	Δp _s
VBI61.50..	Rp 2"	–	–	40...63	50		

¹⁾ Data sheet N4211

²⁾ Data sheet N4212

GLB.. 9E and VA..60.. open/close ball valves 2-port and VB..60.. changeover ball valves 3-port

Ball valves with:					DN	GLB..9E	
internal threads ³⁾	Rp	external threads ⁴⁾	G..B	k _{vs} [m ³ /h]		Δp _{max}	Δp _s
–	–	VAG60.15-9	G 1 B	9	15	350	1400
VAI60.15-15	Rp ½"	–	–	15	15		
–	–	VAG60.20-17	G 1 ¼ B	17	20		
VAI60.20-22	Rp 1"	–	–	22	20		
VAI60.25-22	Rp 1"	VAG60.25-22	G 1 ½ B	22	25		
VAI60.32-35	Rp 1¼"	VAG60.32-35	G 2 B	35	32		
VAI60.40-68	Rp 1½"	VAG60.40-68	G 2 ¼ B	68	40		
VAI60.50-96	Rp 2"	VAG60.50-96	G 2 ¾ B	96	50		600
–	–	–	–	–	–	350	–
VBI60.15-5L	Rp ½"	–	–	5	15		
VBI60.20-9L	Rp 1"	–	–	9	20		
VBI60.25-9L	Rp 1"	–	–	9	25		
VBI60.32-13L	Rp 1¼"	–	–	13	32		
VBI60.40-25L	Rp 1½"	–	–	25	40		
VBI60.50-37L	Rp 2"	–	–	37	50		
–	–	VBG60.15-8T	G 1 B	8	15	350	–
VBI60.15-12T	Rp ½"	–	–	12	15		
–	–	VBG60.20-13T	G 1 ¼ B	13	20		
VBI60.20-16T	Rp 1"	–	–	16	20		
–	–	VBG60.25-13T	G 1 ½ B	13	25		
VBI60.25-16T	Rp 1"	–	–	16	25		
VBI60.32-25T	Rp 1¼"	VBG60.32-25T	G 2 B	25	32		
VBI60.40-49T	Rp 1½"	VBG60.40-49T	G 2 ¼ B	49	40		
VBI60.50-73T	Rp 2"	VBG60.50-73T	G 2 ¾ B	73	50		

³⁾ Data sheet N4213

⁴⁾ Data sheet N4214

Product documentation

Topic	Title	Document ID
Data sheet	Rotary actuators for ball valves	A6V10636203_en--_a
Technical basics	Rotary damper actuators without spring return GL..E	A6V10636196_en--_a
Mounting instructions	GLB..9E	A6V10636201_----_a
Mounting instructions	VAI61.. / VBI61..	M4211
Mounting instructions	VAG61.. / VBG61..	M4212
Mounting instructions	VAI60.. / VBI60..	M4213
Mounting instructions	VAG60.. / VBG60..	M4214

Related documents such as environmental declarations, CE declarations, etc., can be downloaded at the following Internet address:

<http://siemens.com/bt/download>

Safety

	<p>⚠ Caution</p>
	<p>National safety regulations</p> <p>Failure to comply with national safety regulations may result in personal injury and property damage.</p> <ul style="list-style-type: none"> • Observe national provisions and comply with the appropriate safety regulations. • Use only properly trained technicians for mounting, commissioning, and servicing.

Mounting

Both ball valve and rotary actuator can easily be assembled at the mounting location. Neither special tools nor adjustments are required.

Orientation

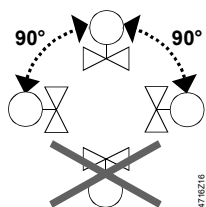

Installation

	<p>⚠ WARNING</p>
	<p>No internal line protection for supply lines to external consumers</p> <p>Risk of fire and injury due to short-circuits</p> <ul style="list-style-type: none"> • Adapt the line diameters as per local regulations to the rated value of the installed fuse.

Commissioning

When commissioning the system, check wiring and the functions of the rotary actuator.

Manual adjustment

The rotary actuator can be manually adjusted into any position between 0° and 90° by pushing the gear train disengagement slider.

If a control signal from the controller is present, this will take priority in determining the position after the slider is released.

For manual adjustment: Power off!

Maintenance

The actuators GLB..9E are maintenance-free.



The device is considered an electronics device for disposal in terms of European Directive 2012/19/EU and may not be disposed of as domestic garbage.

- Dispose of the device through channels provided for this purpose.
- Comply with all local and currently applicable laws and regulations..

Technical data

Power supply (GLB1..9E)		
Operating voltage (SELV/PELV) / Frequency		AC 24 V ~ ±20 % (19,2...28,8 V ~) / 50/60 Hz DC 24...48 V = ±20 % (19,2...57,6 V =) ¹⁾
Power consumption running	GLB141.9E, GLB161.9E	3 VA / 1.5 W 2.5 VA / 1.5 W
Power consumption holding	GLB141.9E, GLB161.9E	0.5 W 0.7 W
Power supply (GLB341.9E)		
Operating voltage / Frequency		AC 100...240 V ~ ±10 %; 50 / 60 Hz
Power consumption running Power consumption holding		6 VA / 2 W 0.9W
Function data		
Nominal torque		10 Nm
Maximum torque (blocked)		16 Nm
Minimum holding torque		10 Nm
Nominal rotary angle (with position indication)		90°
Maximum rotary angle (mechanic limitation)		95° ± 2°
Runtime for 90° rotary angle		150 s
Actuator sound power level		28 dB(A)
Inputs		
Positioning signal for GLB141.9E		
Operating voltage	(wires 1-6/G-Y1)	clockwise
AC 24 V ~ / DC 24...48 V =	(wires 1-7/G-Y2)	counterclockwise
Positioning signal for GLB341.9E		
Operating voltage	(wires 4-6/N-Y1)	clockwise
AC 100...240 V ~	(wires 4-7/N-Y2)	counterclockwise
Positioning signal for GLB161.9E		
Input voltage	(wires 8-2/Y-G0)	DC 0/2...10 V =
Current consumption		0.1 mA
Input resistance		>100 kΩ
Max. permissible input voltage		DC 35 V = limited to DC 10 V =
Protected against faulty wiring		max. AC 24 V ~
Hysteresis		60 mV
Outputs		
Position indicator (GLB161.9E)		
Output signal	(wires 9-2/U-G0)	DC 0...10 V =
Output voltage U		DC ±1 mA
Max. output current		max. AC 24 V ~ / DC 24...48 V =
Protected against faulty wiring		

Connection cables	
Cable length	0.9 m
Cross section of prewired connection cables	0.75 mm ²
Permissible length for signal lines	300 m
Degree of protection	
Insulation class AC 24 V ~ / DC 24...48 V \equiv AC 100...240 V ~	As per EN 60730 III II
Housing protection	IP 54 as per EN 60529
Environmental conditions	
Operation Climatic conditions Mounting location Temperature extended Humidity (non-condensing)	IEC 60721-3-3 Class 3K5 interior, weather-protected -32...+55 °C <95 % r.F.
Transport Climatic conditions Temperature extended Humidity (non-condensing)	IEC 60721-3-2 Class 2K3 -32...+70 °C <95 % r.F.
Storage Climatic conditions Temperature extended Humidity (non-condensing)	IEC 60721-3-1 Class 1K3 -32...+50 °C <95 % r.F.
Mechanical conditions	Class 2M2
Standards, directives and approvals	
Product standard	EN60730 Part 2-14 / Particular requirements for electric actuators
Electromagnetic compatibility (Applications)	For use in residential, commercial, light-industrial and industrial environments
EU Conformity (CE)	A5W00000176 ²⁾
RCM Conformity	A5W00000177 ²⁾
EAC Conformity	Eurasian conformity
UL	60730 http://ul.com/database
Environmental compatibility	
The product environmental declaration A5W00026068 ²⁾ contains data on environmentally compatible product design and assessments (RoHS compliance, materials composition, packaging, environmental benefit, disposal).	
Dimensions	
Actuator W x H x D	see „Dimensions“, p. 9
Weight	
Without packaging	0.69 kg

¹⁾ C-UL: Permitted only to DC 30 V \equiv

²⁾ The documents can be downloaded from <http://siemens.com/bt/download>.

Internal Diagrams

GLB141.9E (open-close, three-p.)

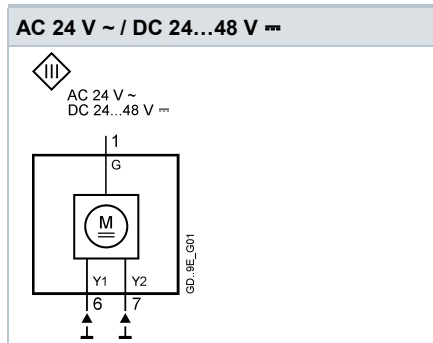

GLB161.9E (modulating)

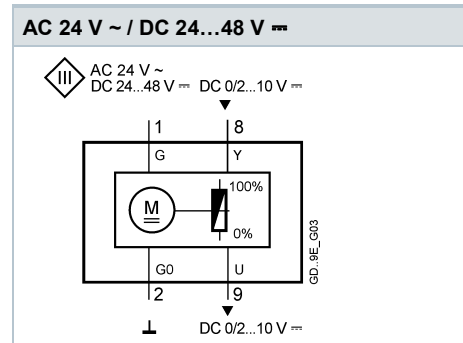

GLB341.9E (open-close, three-p.)

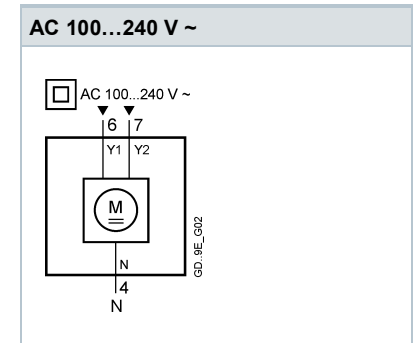

Connection diagrams

GLB1..9E (AC 24 V ~ / DC 24...48 V ~)

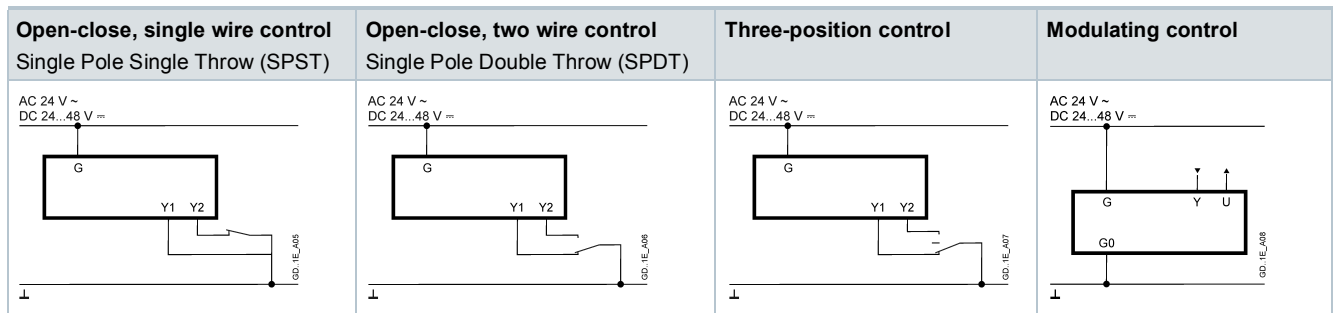

GLB341.9E (AC 100...240 V ~)

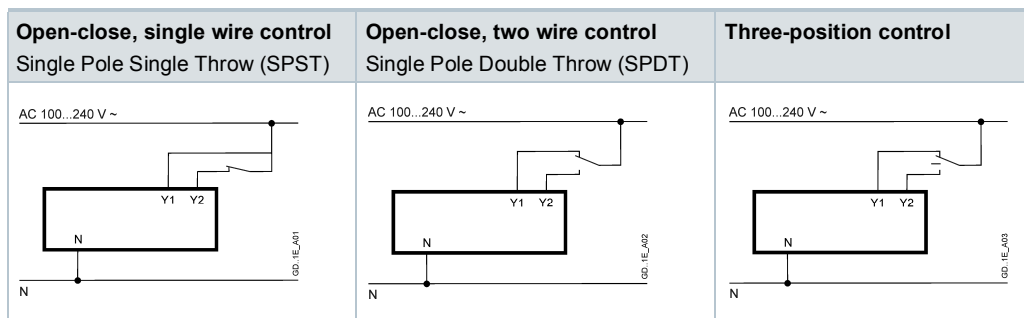

Cable labeling

Pin	Code	No	Color	Abbreviation	Meaning
Actuators	G	1	red	RD	System potential AC 24 V ~ / DC 24...48 V =
AC 24 V ~	G0	2	black	BK	System neutral
DC 24...48 V =	Y1	6	purple	VT	Positioning signal AC/DC 0 V, "clockwise" (GLB141.9E)
	Y2	7	orange	OG	Positioning signal AC/DC 0 V, "counter-clockwise" (GLB141.9E)
	Y	8	grey	GY	Signal in (GLB161.9E)
	U	9	pink	PK	Signal out (GLB161.9E)
Actuators	N	4	blue	BU	Neutral conductor
AC 100...240 V ~	Y1	6	black	BK	Positioning signal AC 100...240 V ~, "clockwise" (GLB341.9E)
	Y2	7	white	WH	Positioning signal AC 100...240 V ~, "counter-clockwise" (GLB341.9E)

Dimensions

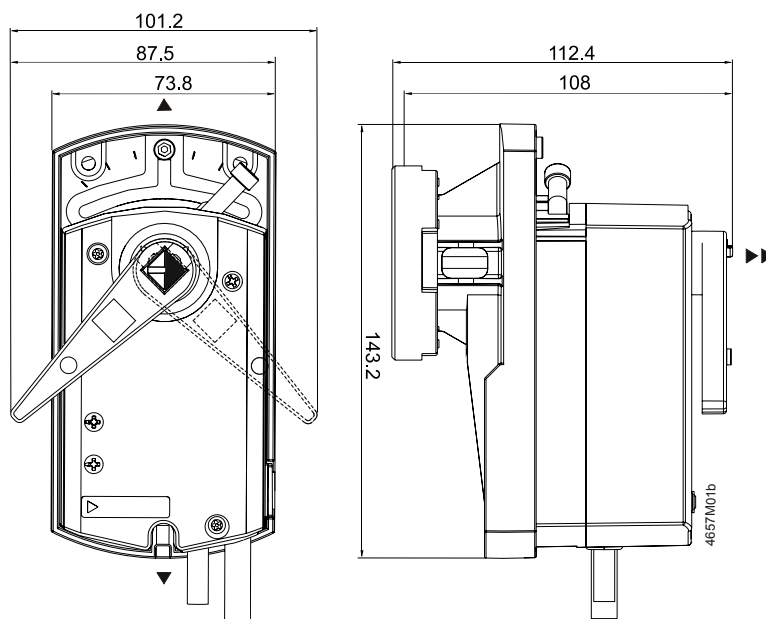

Dimensions in mm

▶ = > 100 mm

▶▶ = > 200 mm

Minimum clearance from ceiling or wall for mounting, connection, operation, maintenance etc.

Issued by
Siemens Switzerland Ltd
Building Technologies Division
International Headquarters
Gubelstrasse 22
6301 Zug
Switzerland
Tel. +41 41-724 24 24
www.siemens.com/buildingtechnologies

© Siemens Switzerland Ltd, 2016
Technical specifications and availability subject to change without notice.

Document ID A6V10636203_en--_a
Issue 2016-09-20